

MF-300 SERIES

'Medium Flow' Pressure Reducing Regulator Piston Sensed for outlet control to 200bar / 2900psi

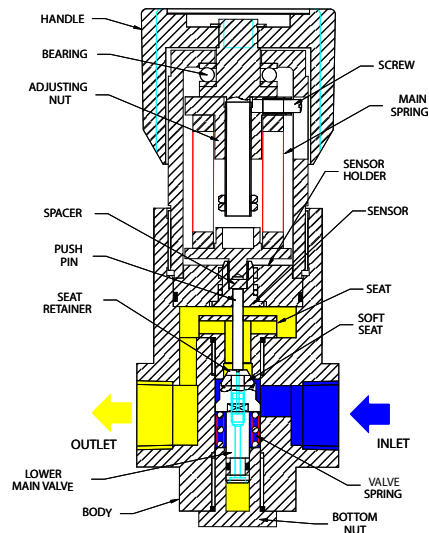

*Assembly drawing for reference only. Refer to office for specific detail.

The MF-300 provides control of pressures up to 200bar outlet pressure, and has a balanced main valve to minimize effect of decaying inlet pressure. The seating design incorporates protection against dynamic loads hitting the sensing element as the main valve open, hence providing stable control and hunting of the regulator. A lower entry plug also provides easy servicing of the PCTFE seat.

APPLICATIONS:

- Compressed air systems
- Gas Quads
- Diving applications
- Automated pressure cycling
- Pipeline test systems

FEATURES:

300bar / 4350psi inlet pressure
 Precision machined sensing elements
 PCTFE seat fitted to main valve to help protect from potential particle damage
 Excellent sensitivity
 Self venting and non venting options

STANDARD MATERIALS OF CONSTRUCTION

| Regulator part | Material |
|-------------------|--------------------|
| Body and Bonnet | 316SS |
| Main valve pin | 316SS |
| Seat | PCTFE |
| Valve spring | 302SS |
| Sensor and Holder | 316SS |
| Handwheel | Nylon |
| Push pin | 316SS |
| Spring rests | 316SS |
| 'O' ring seals | NBR, Viton or EPDM |
| Adjusting screw | Alu Bronze |
| Loading Spring | Spring Steel |
| Lubricant | Krytox GPL 205 |

NOTE: Product availability and specifications contained herein are subject to change without notice. Consult local distributor or factory for potential revisions and/or service related issues. // pg 1 of 2

PRESSURE TECH LTD, Unit 6, Graphite Way, Hadfield, Glossop, Derbyshire SK13 1QG
 Tel: +44 (0)1457 899307 Fax: +44 (0)1457 899308
 e-mail: info@pressure-tech.com



www.pressure-tech.com

Designed and built in the UK



MF-300 SERIES

'Medium Flow' Pressure Reducing Regulator Piston Sensed for outlet control to 200bar / 2900psi

INSTALLATION DIMENSIONS:

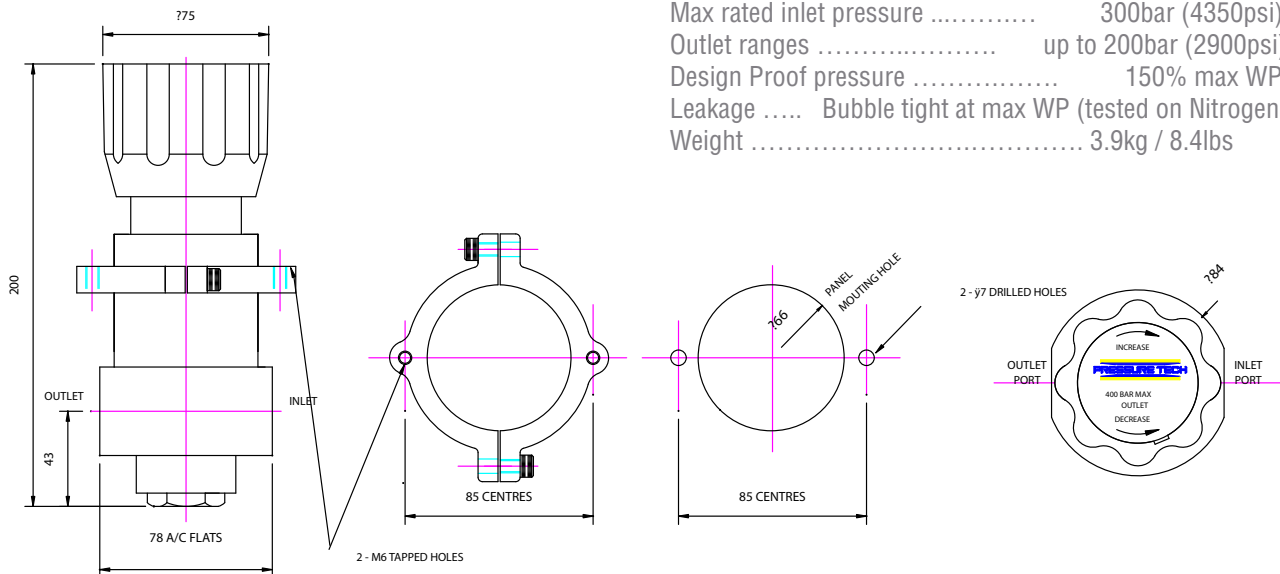

SPECIFICATION :

Max rated inlet pressure 300bar (4350psi)
 Outlet ranges up to 200bar (2900psi)
 Design Proof pressure 150% max WP
 Leakage Bubble tight at max WP (tested on Nitrogen)
 Weight 3.9kg / 8.4lbs

ORDERING INFORMATION:

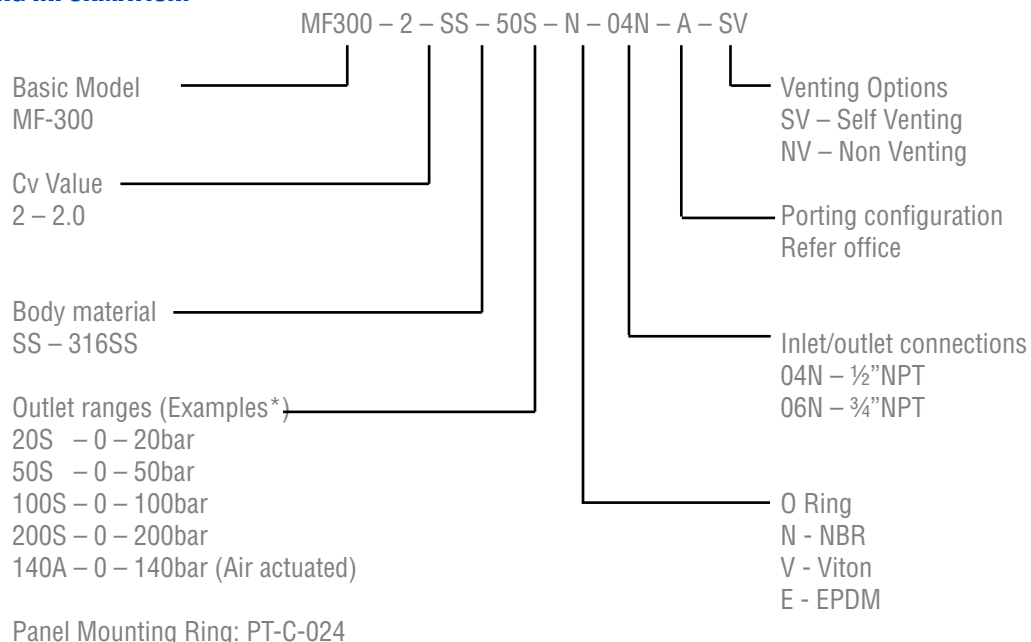

NOTE: Product availability and specifications contained herein are subject to change without notice. Consult local distributor or factory for potential revisions and/or service related issues. // pg 2 of 2