

# XHR-300 Series

'Low Flow' Electric and Steam Heated Regulator Diaphragm Sensed for outlet control to 35bar / 500psi

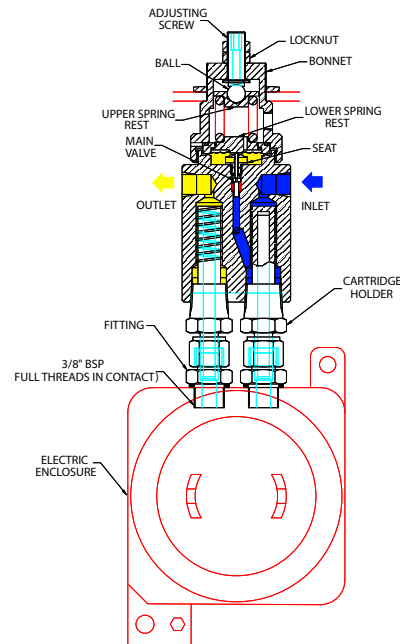

Assembly drawing for reference only. Refer to office for specific detail

Certified to ATEX directive 94/9/EC, the XHR-300 helps to maintain saturated gases in their vapourised state due to its unique DUAL heating design. Two 100W heater cartridges, or steam tubes, are inserted in spiral machined sheaths, which agitate the media to help with the heat transfer and analysis process. The propriety PCB is easy to wire and incorporates an adjustable potentiometer to adjust the temperature setting to the heaters.

### Applications:

- Natural Gas sample systems
- Oxygen sample systems
- Moisture sample systems

### Features:

ATEX certified to EEx d IIC T3  
 Dual, independent, 100W heaters for pre heat and re-heat of sample gas. Oxygen sample - Inconel X750 Diaphragm for extra strength  
 Large surface area for heat transfer  
 Easy to wire circuit board with 115V or 230V supply  
 Stylish Junction Box with 7mm mounting supports.  
 Fully serviceable design  
 Optional entry points for cable supply

### STANDARD MATERIALS OF CONSTRUCTION

Regulator part	Material
Body and Bonnet	316SS
Main valve pin	316SS
Soft seat cone	PEEK
Valve spring	Inconel X750
Diaphragm	Inconel X750
Handwheel	Nylon
Diaphragm washer	Brass
Cartridge Holder	316SS
'O' ring seals	Viton
Adjusting screw	Ali Bronze
Electric Enclosure	Coated Aluminium
Compression Fitting	316SS

NOTE: Product availability and specifications contained herein are subject to change without notice. Consult local distributor or factory for potential revisions and/or service related issues. // pg 1 of 2

PRESSURE TECH LTD, Unit 6, Graphite Way, Hadfield, Glossop, Derbyshire SK13 1QG  
 Tel: +44 (0)1457 899307 Fax: +44 (0)1457 899308  
 e-mail: info@pressure-tech.com

[www.pressure-tech.com](http://www.pressure-tech.com)



Designed and built in the UK



# XHR-300 Series

'Low Flow' Electric and Steam Heated Regulator Diaphragm Sensed for outlet control to 35bar / 500psi

## INSTALLATION DIMENSIONS:

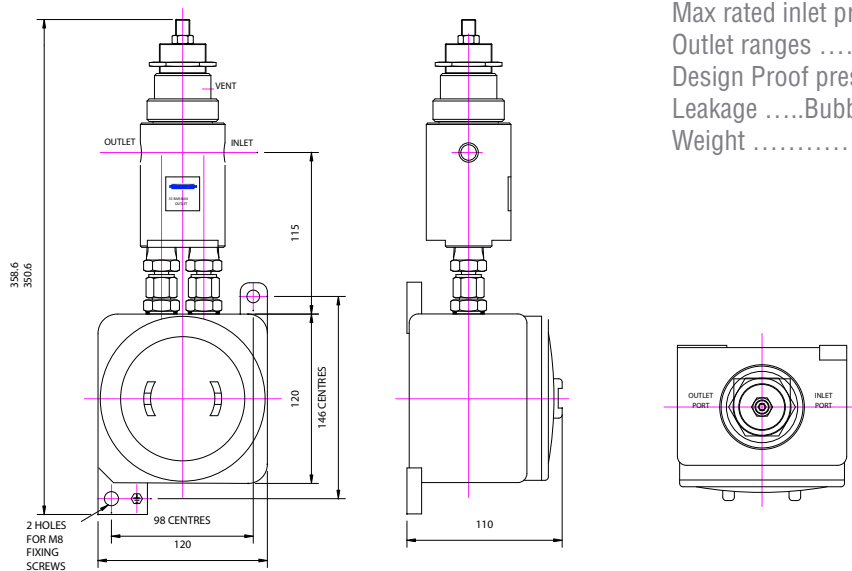

## SPECIFICATION :

Max rated inlet pressure ..300bar (4350psi) with PEEK seat  
 Outlet ranges ..... up to 35bar (500psi)  
 Design Proof pressure ..... 150% max WP  
 Leakage .....Bubble tight at max WP (tested on Nitrogen)  
 Weight ..... 4.1kg (2lbs)

## ORDERING INFORMATION:

XHR300 - 06 - SS - 10 - 1 - L - A

Basic Model  
XHR300

Cv Value  
06 - 0.06

Body material  
SS - 316SS

Outlet ranges (Examples\*)  
 02 - 0 - 2bar  
 04 - 0 - 4bar  
 08 - 0 - 8bar  
 10 - 0 - 10bar  
 20 - 0 - 20bar

\* Maximum outlet pressure can be set to specific requirements

Porting configuration  
Refer to office

Power cable supply  
 L - Left side  
 R - Right side  
 B - Bottom side

Heat supply  
 1 - 115V  
 2 - 230V  
 S - Steam

Panel Mounting Ring: PT-C-024

NOTE: Product availability and specifications contained herein are subject to change without notice. Consult local distributor or factory for potential revisions and/or service related issues. // pg 2 of 2

PRESSURE TECH LTD, Unit 6, Graphite Way, Hadfield, Glossop, Derbyshire SK13 1QG  
 Tel: +44 (0)1457 899307 Fax: +44 (0)1457 899308  
 e-mail: info@pressure-tech.com

[www.pressure-tech.com](http://www.pressure-tech.com)



Designed and built in the UK

